

NOTE:
 STEEL MANUFACTURER TO
 PROVIDE CONTINUOUS WELDS
 AT ALL JOINTS. GRIND ALL
 WELDS SMOOTH.

NOTE:
 HANDRAIL DOES NOT OCCUR
 AT ALL LOCATIONS.
 COORDINATE HEIGHT WITH
 HANDRAIL DESIGN.

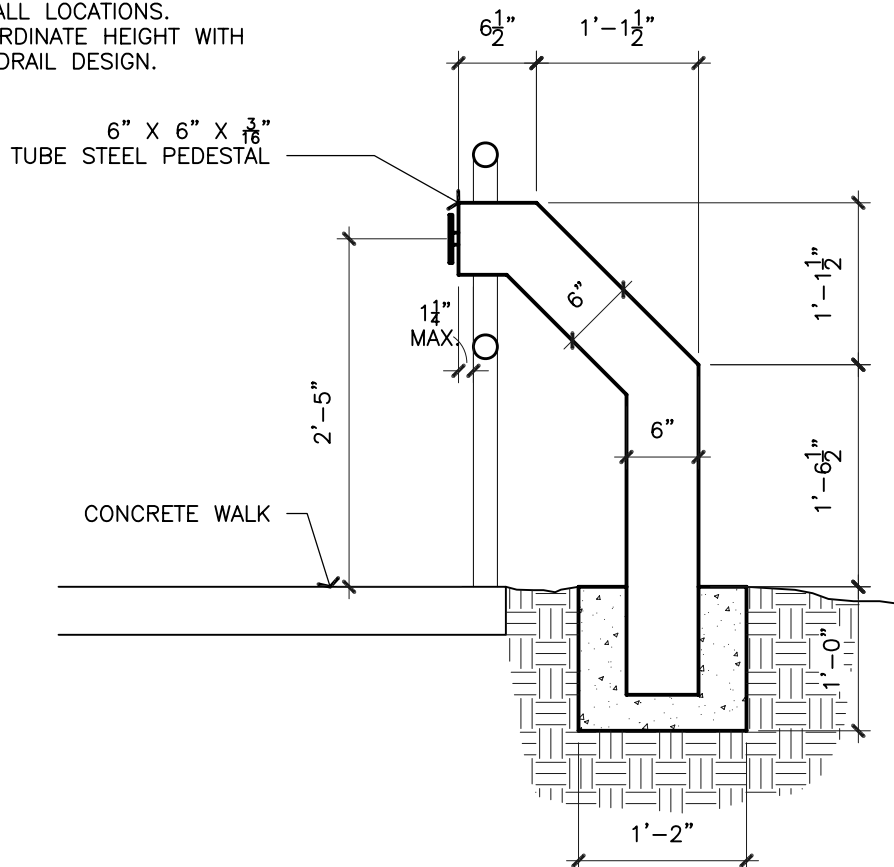

DOOR OPENER PEDESTAL TYPE 2

SCALE: 3/4"=1'-0"

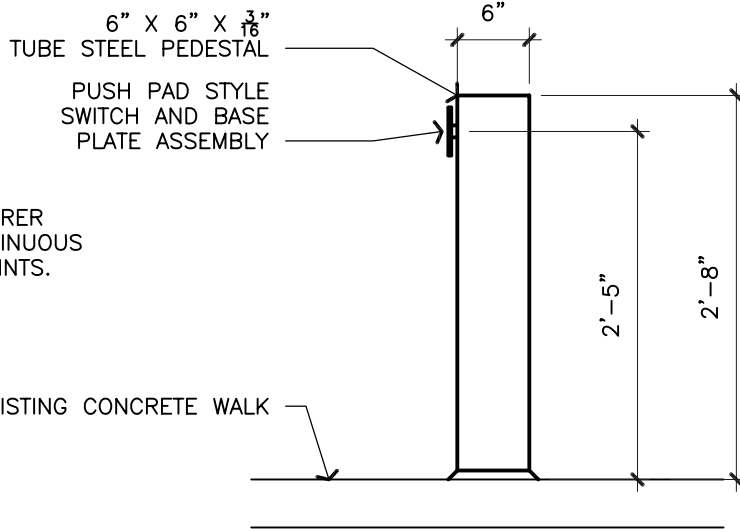

NOTE:
STEEL MANUFACTURER
TO PROVIDE CONTINUOUS
WELDS AT ALL JOINTS.
GRIND ALL WELDS
SMOOTH.

DOOR OPENER PEDESTAL TYPE 1

SCALE: 3/4"=1'-0"